

ORBIT 503 Standard

*Compact
Trailer-Mounted
Mini Crane
(230 V Electric Drive)*



Orbit 503 Standard is a compact trailer-mounted mini crane with an electro-hydraulic drive, designed for lifting and handling materials in confined and hard-to-access locations where conventional cranes are impractical or uneconomical.

The crane operates on an electro-hydraulic principle: a 230 V single-phase power supply feeds a frequency inverter that drives the hydraulic power unit, while a solid-state-relay-based control system manages crane movements and essential safety functions.

Rated lifting capacity	500 kg
Maximum lifting capacity	Up to 1000 kg
Maximum boom reach	Up to 10 m
Power supply	1×230 V AC, 50 Hz; selectable 16 A / 32 A operating profiles
Principle of operation	Electro-hydraulic system with frequency-controlled hydraulic power unit and solid-state-relay-based control



Typical Applications

- Residential and small commercial construction (private houses, extensions, small industrial units)
- Glazing, façade and cladding installation (windows, balcony elements, curtain walls)
- Rooftop works: HVAC units, compact equipment, solar panels and skylights
- Renovation and retrofitting in dense urban areas with restricted access (courtyards, backyards, inner yards)
- Industrial and maintenance tasks: placing small machinery, platforms and components on mezzanines and roofs
- Work on unprepared or remote sites using a 230 V power supply or a portable generator
- Low-emission and low-noise environments where combustion-engine equipment is undesirable

Key Features & Benefits

- Fully electric drive – no combustion engine: low noise, zero local emissions, suitable for low-emission and noise-sensitive job sites.
- 230 V single-phase supply with Eco (16 A) and Performance (32 A) profiles: can run from standard sockets or dedicated feeds / generators.
- Integrated load-holding valves on winch, boom and slew functions: safe load holding and controlled lowering, even in case of hose or line failure.
- Simple solid-state-relay-based control architecture: essential safety functions only, with overload protection, over-hoist protection and emergency stop via safety relay and VFD STO.
- Wireless radio remote with precision mode: safe operating distance and fine positioning of loads in confined and hard-to-access areas.
- Compact trailer-mounted design: quick to position, set up and relocate around the site using a light vehicle..

Technical Specifications

Lifting Performance

Rated lifting capacity (SWL)	500 kg (at typical working radius; see load chart)
Maximum lifting capacity	Up to 1000 kg (depending on radius; see load chart)
Maximum boom reach	Up to 10 m (from slewing axis to hook)
Winch	Hydraulic winch with factory-fitted overcenter valve block
Slewing range	360° around vertical axis

Hydraulic System

Power pack	3 kW electro-hydraulic unit, pump flow approx. 9 L/min, max. system pressure 175 bar
Valve bank	3-section open-centre valve bank (Z50 series) for winch, slew and boom cylinder
Tank volume	12 L usable hydraulic oil volume
Cooling & filtration	Oil-air cooler in return line + 10 µm return filter with clogging indicator
Load-holding valves	Integrated overcenter (load-holding) valves on winch, slew motor and boom cylinder for safe load holding and controlled lowering



ORBIT 503 Standard

Working Geometry

Maximum hook height, outreach and working sector depend on the installation height of the crane, boom angle and slewing range. Refer to the dimensional drawing (side and top view) and the load chart for exact values.

Parameters in transport position

Stowed dimensions (L x W x H)	3.5 x 1.75 x 1.95 m
Crane weight	1350 kg

Electrical Supply & Control

Supply	1×230 V AC, 50 Hz; selectable 16 A (Eco) / 32 A (Performance) operating profiles
Drive	1→3 phase frequency inverter (VFD), 4 kW rating, heavy-duty mode
Control system	PLC-based control system, 24 V DC I/O, safety relay (PL e, Cat. 4) + VFD STO
Remote control	Wireless radio remote with E-STOP and precision (slow) movement mode

Safety & Standards

Orbit 503 Standard incorporates essential safety functions, including overload protection, over-hoist protection, and an emergency stop circuit with a safety relay (PL e, Cat. 4) acting on the VFD STO inputs. The crane is designed in accordance with applicable EU machinery safety requirements, including EN ISO 12100, EN ISO 13849-1 and EN 60204-1/-32, and is supplied with an EU Declaration of Conformity.

Power Supply & Generator Requirements

Orbit 503 Standard is designed to operate from a standard 1×230 V AC, 50 Hz single-phase supply or from a suitable single-phase generator. Two operating profiles – Eco (16 A) and Performance (32 A) – allow the crane to run from common 16 A sockets or from dedicated 32 A feeds with full performance. For generator operation, CranexPro recommends a minimum continuous rating of approx. 4 kVA in Eco mode and 7–8 kVA in Performance mode, using an AVR or inverter-type generator with low voltage distortion.

Figure 1

Load chart, boom fully extended (maximum outreach)

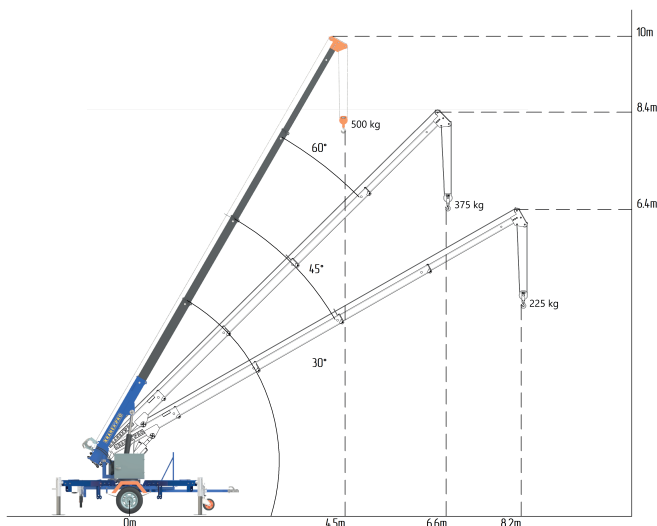

Figure 2

Load chart, boom extended to 4 sections (heavy-duty configuration)

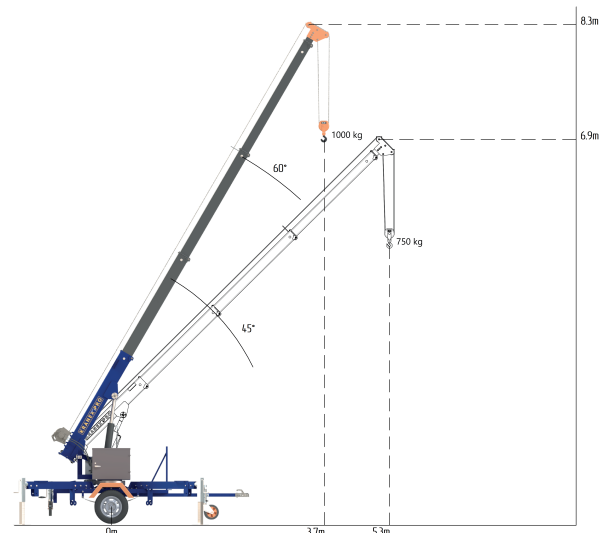
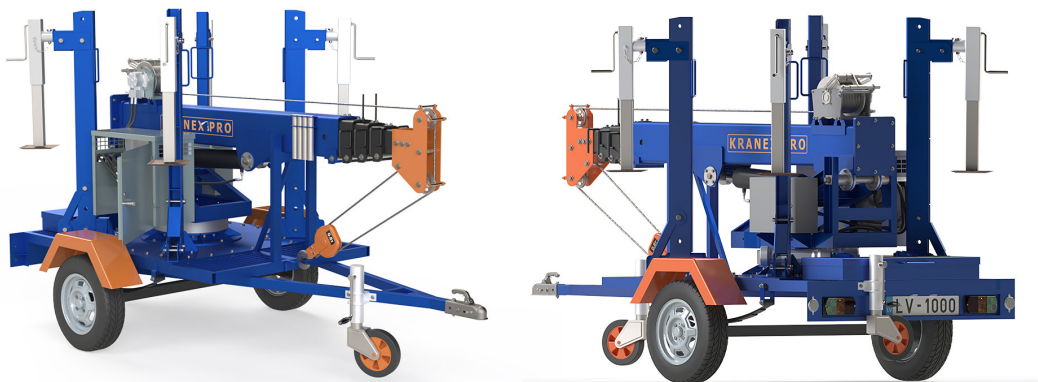
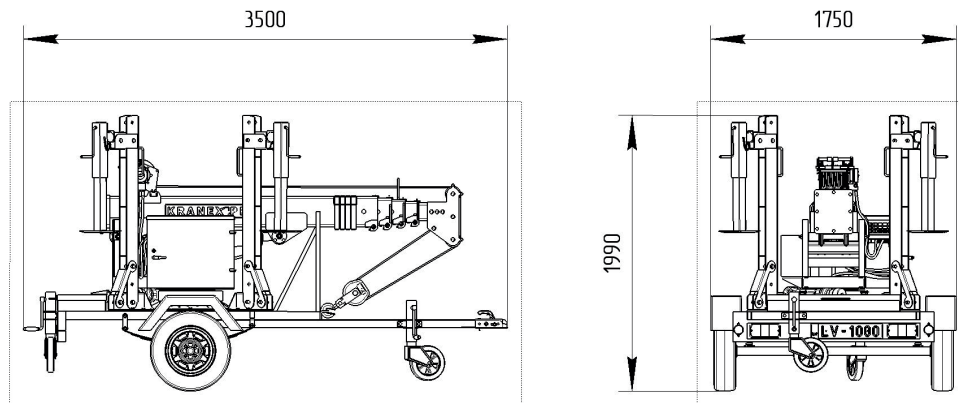

Figure 3

Overall dimensions in transport (stowed) position



Options & Accessories

A range of options and accessories is available to adapt Orbit 503 Standard to specific jobs and site conditions, including:

- **Lifting accessories:** optional winch rope lengths and reeving, fixed or adjustable spreader beams, hooks and shackles, interfaces for glass vacuum lifters and other specialist lifting devices
- **Mounting & support:** custom trailer or base frames, additional outrigger pads, support mats and leveling wedges for soft or uneven ground
- **Power & control:** extended power and control cable sets, alternative plug / inlet configurations, additional or backup radio remote
- **Lighting & signalling:** LED work lights on the boom or chassis, amber warning beacon, acoustic alarm (buzzer) for crane movements

Availability of specific options may vary by configuration and market; detailed option lists are available on request.